

FASTER & FURTHER

NOW INTRODUCING
THE STRONGEST
44' IN THE MARKET



Wall-Board Serie 44' - 52' - 60'

Since 1959



Cranes, in all the languages of the world

WB 60'

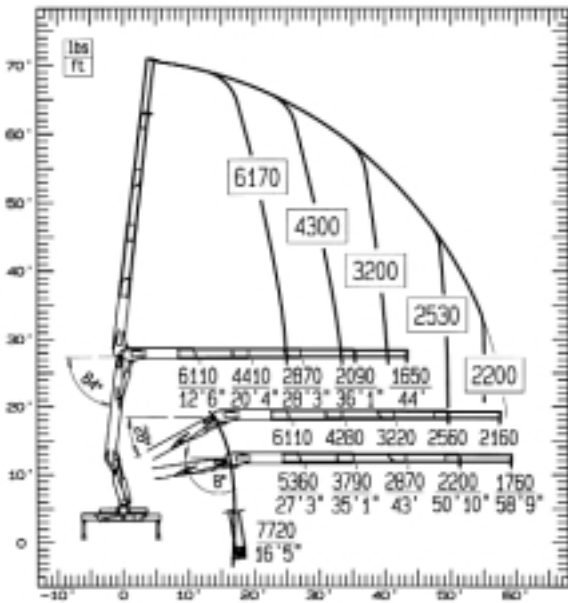

WB 44'

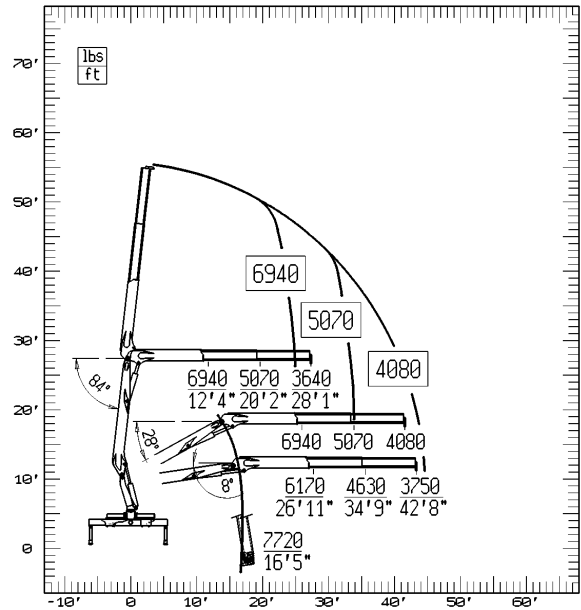

WB 52'

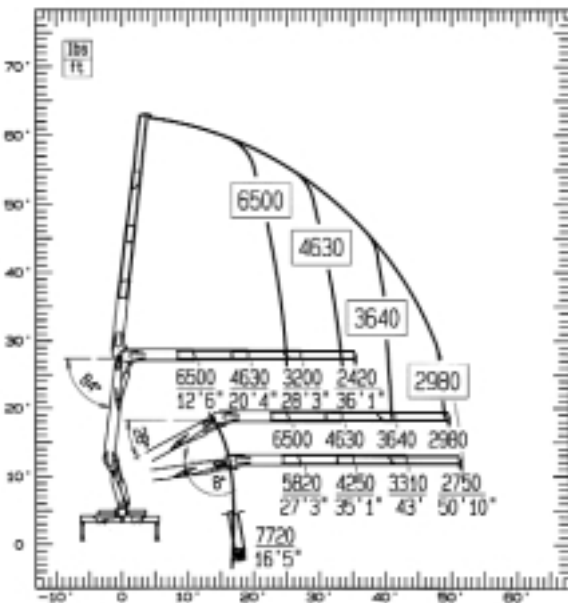

WORKING TIMES

		WB 44'	WB 52'	WB 60'
Extension time (15'9")	sec.	14	--	--
Retraction time (15'9")	sec.	14	--	--
Extension time (23'7")	sec.	--	22	--
Retraction time (23'7")	sec.	--	21	--
Extension time (31'6")	sec.	--	--	30
Retraction time (31'6")	sec.	--	--	28
Rotation 360°	sec.	30-60	30-60	30-60
Inner Boom elev. time	sec.	33	33	33
Outer Boom elev. time	sec.	40	40	40

THE WEIGHT OF WALLBOARD FORK AND ROTATOR MUST BE DEDUCTED FROM LIFTING CHART



WB 60'

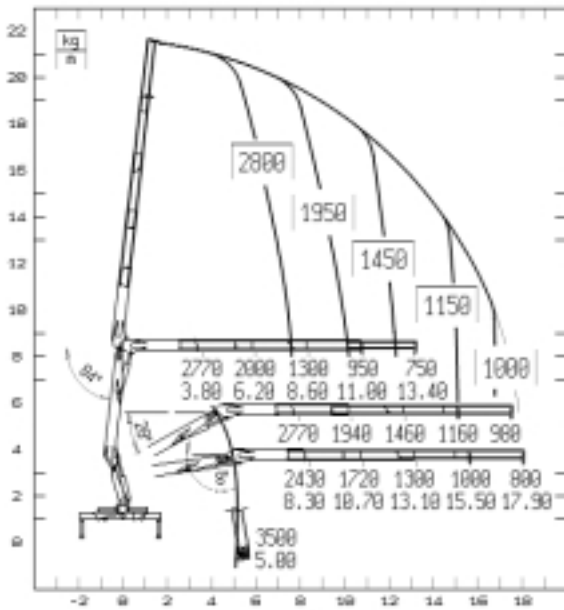

WB 44'



INSTALLATION

MINIMUM CARRIER Tandem axle frame
 RBM 2,5 million (per rail) WB
 FA 12,000 lbs RA 34,000 lbs GWV 46,000 lbs

RECOMMENDED CARRIER Tandem axle frame
 RBM 2,5 million (per rail) WB
 FA 16,000 lbs RA 40,000 lbs

WB 52'

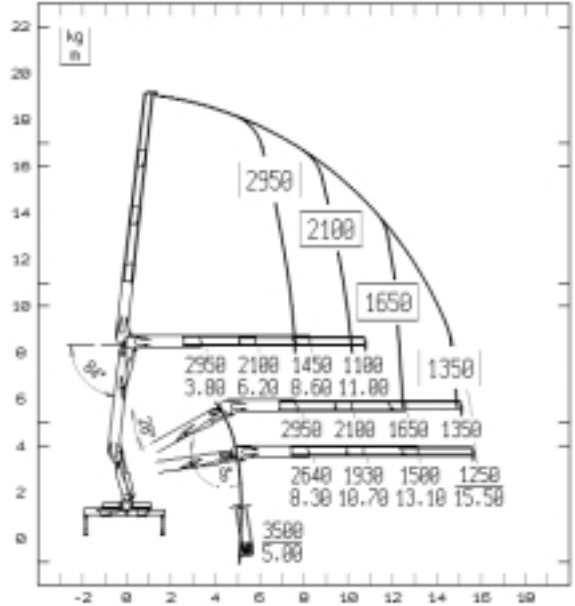

THE WEIGHT OF WALLBOARD FORK AND ROTATOR MUST BE DEDUCTED FROM LIFTING CHART





CONTROL STATION

The control station of the standard crane is fitted with joysticks and pedals, load indicator, PM moment control device, emergency button, platform and two ladders for access. The control valve block and its protection guard are located under the seat and guarantee excellent visibility. The controls are in easily accessible and comfortable positions.

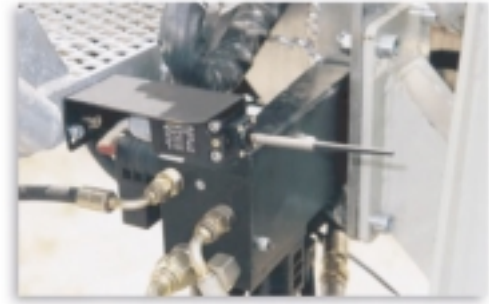

BEEPER

The microswitch activates a beeper to warn the operator that crane is operating below its horizontal, thus preventing the load or equipment from getting damaged.



RADIO CONTROL

The WB Series is available in the fully proportional remote control version without the top seat. The WB Series features a radio control that optimises performance, reduces working time and maintains the same uses of the top control station.



CONTROL STATION

The top control station of the WB Series is positioned level with the main boom, in order not to interfere with the load as it is being handled. The tip-over seat can be moved forwards or back-ward to obtain the most comfortable control position.



DOUBLE-ACTING CHECK VALVE

The check valves for the down movement out of outrigger cylinders are double-acting type. They have a very low stabilising time, as it is no longer necessary to act on the valve closing lever.

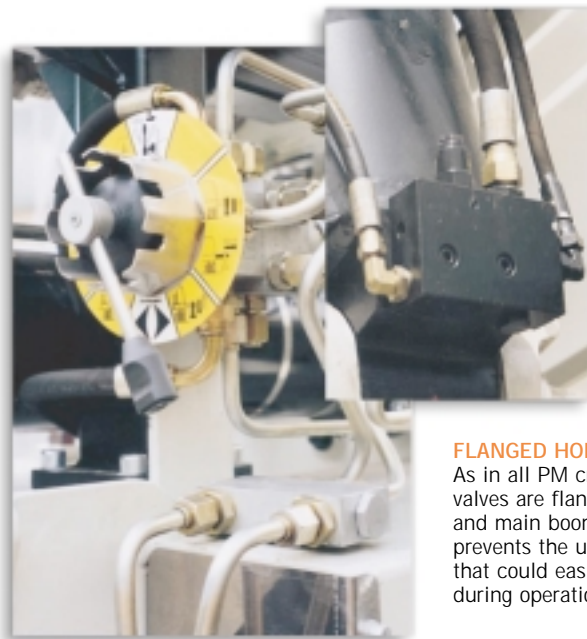

FLANGED HOLDING VALVES

As in all PM cranes the check valves are flanged to the column and main boom cylinder; this prevents the use of external pipes that could easily get damaged during operation.

FLOW DIVIDER

The out & down control of the outriggers is of the standard PM type and features an 8-position flow divider that enables the down movement of the out-riggers even on one side of the equipment only. The double-acting valves are also fitted on the lateral hydraulic extension (22'1" in XL version).



OUTER BOOM CYLINDER GUARD

A high resistance guard protects outer boom cyl from getting accidentally damaged by the load or by the straps. The extension cylinder pins are easy to access.



MECHANICAL STOP

The mechanical locking system between the main boom and boom unit prevents particular set-ups of the crane, that do not depend on normal use or that concern transport, from damaging the main boom cylinder.

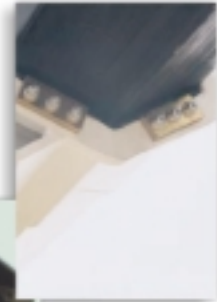

BOTTOM WEAR PADS

The bottom wear pad fixing system guarantees easy control and replacing.



ACTIVATION TERMINALS

The terminals of the activations are vertical to eliminate the presence of bends in the pipes connected to the Fork & rotator. The round pads for side clearance adjustments are located above the boom and feature a mechanical safety device.



CATTRACKS

BULK HEAD FITTINGS

SUPPLEMENTARY ACTIVATIONS

The activations for rotator and forks are protected by high resistance ducts. The pipes are protected by sheaths to guarantee the maximum reliability.



Visibility from control position; the activations are on the same side of the control station to enable every movement to be kept under control; the metal pipes have a larger diameter to considerably increase hydraulic extension speed and prevent the oil from overheating.

INTERNAL CYLINDERS

To offer improved protection, the boom extension cylinders are fully enclosed within the boom unit. Easy maintenance: all cylinders can be removed by taking off the hinge pins.



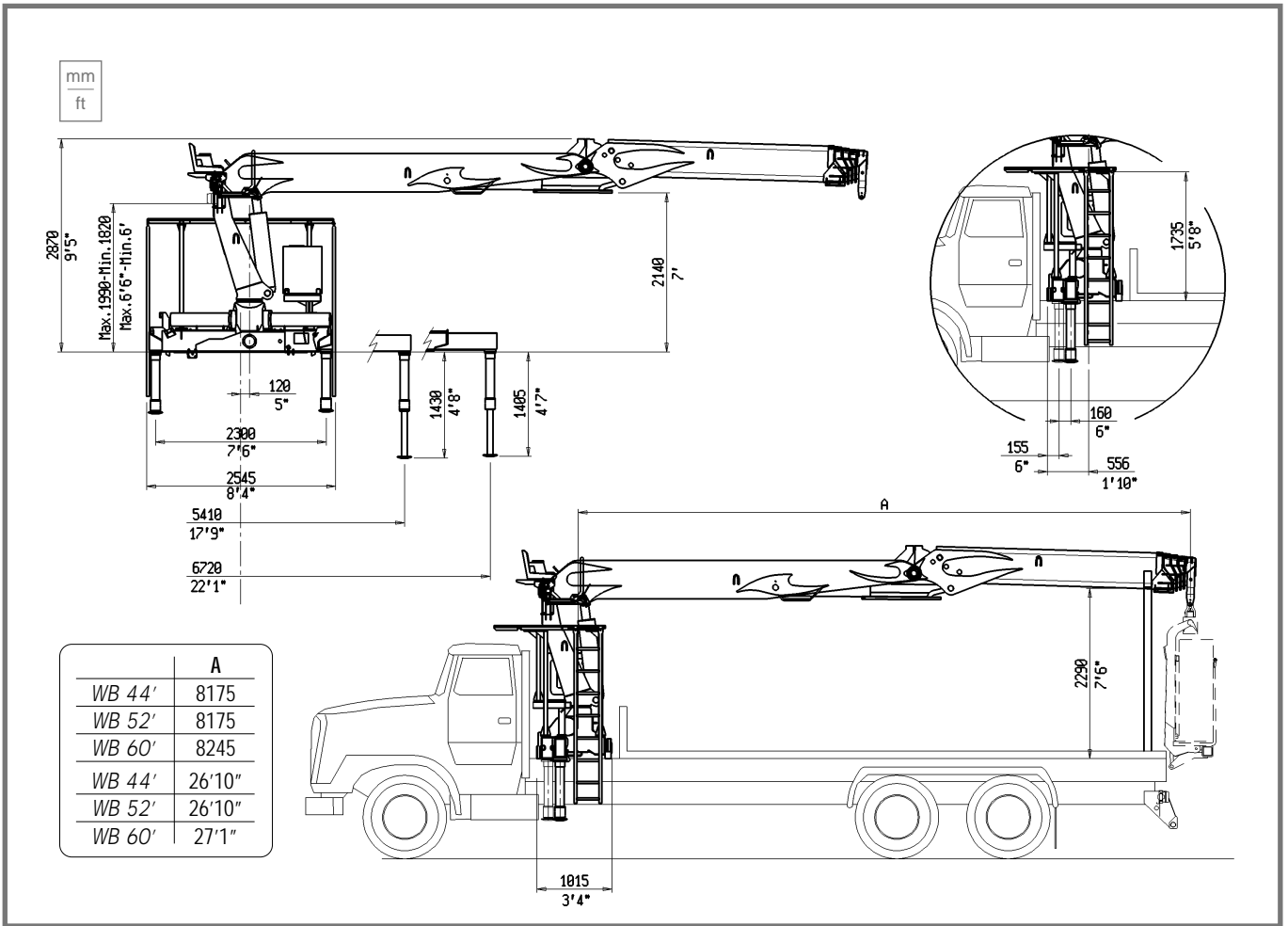

TECHNICAL DATA

		<i>WB 44'</i>	<i>WB 52'</i>	<i>WB 60'</i>
MAXIMUM LIFTING MOMENT -	ft lbs	172900 (24'11" · 6940lbs)	162000 (24'11" · 6500lbs)	151900 (24'11" · 6110lbs)
MAXIMUM HYDRAULIC REACH				
HORIZONTAL -	ft	43'	51'2"	59'1"
VERTICAL -	ft	54'11"	61'4"	69'3"
HYDRAULIC SYSTEM				
RECOMMENDED OIL FLOW -	gals/min (USA)	12+12	12+12	12+12
RATED PRESSURE -	psi	3555	3555	3555
TANK CAPACITY -	gals (USA)	53	53	53
SLEWING SYSTEM				
SLEWING ANGLE -	°	408	408	408
SLEWING MOMENT -	ft lbs	32550	32550	32550
MAX. WORKING HEEL -	% (°)	8,7(5)	8,7(5)	8,7(5)
STANDARD CRANE WEIGHT WITH NON FULL TANK* -	lbs	9150	9660	10185
WEIGHT OF RUNNING BOARD -	lbs	440	440	440
WEIGHT OF ANCHORAGE -	lbs	145	145	145
WEIGHT OF OIL TANK REFUELING -	lbs	350	350	350
MAXIMUM POWER ABSORBED BY THE HYDRAULIC PUMP -	HP	49	49	49

*WITH OUTRIGGERS XL AND 1°+2° ACTIVATIONS



CRANES, IN ALL THE LANGUAGES OF THE WORLD

ARGENTINA
AUSTRALIA
BELGIUM
BRAZIL
CANADA
CHILE
COLOMBIA
CZECH REP
CYPRUS
DENMARK
EGYPT
EAST/NORTH EUROPE
EIRE
FINLAND
FRANCE
GERMANY
GREECE
HONG KONG
INDONESIA
ITALY
JORDAN
MALAYSIA
MALTA
MEXICO
MOROCCO
NORWAY
OCEANIA
NETHERLANDS
PERU
PHILIPPINES
POLAND
PORTUGAL
P.R.C.
QUATAR
ROMANIA
SAUDI ARABIA
SINGAPORE
SPAIN
SOUTH AFRICA
SOUTH AMERICA
SWITZERLAND
THAILAND
TAIWAN
TOBAGO
TRINIDAD
TUNISIA
TURKEY
UNITED ARAB EMIRATES
USA
UK
VENEZUELA
VIETNAM



Autogru PM spa - via Emilia Est, 1058 - 41100 Modena MO (ITALY)
Tel. +39 059 20.54.711 - Fax +39 059 28.07.47 - Export Fax +39 059 28.25.05
e-mail: autogrupm@autogrupm.com www.autogrupm.com