

Since 1959

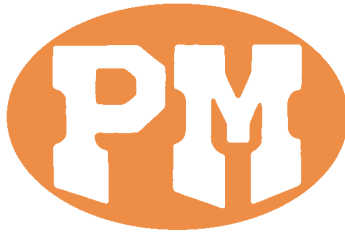

Cranes, in all the languages of the world

Serie 45 SP

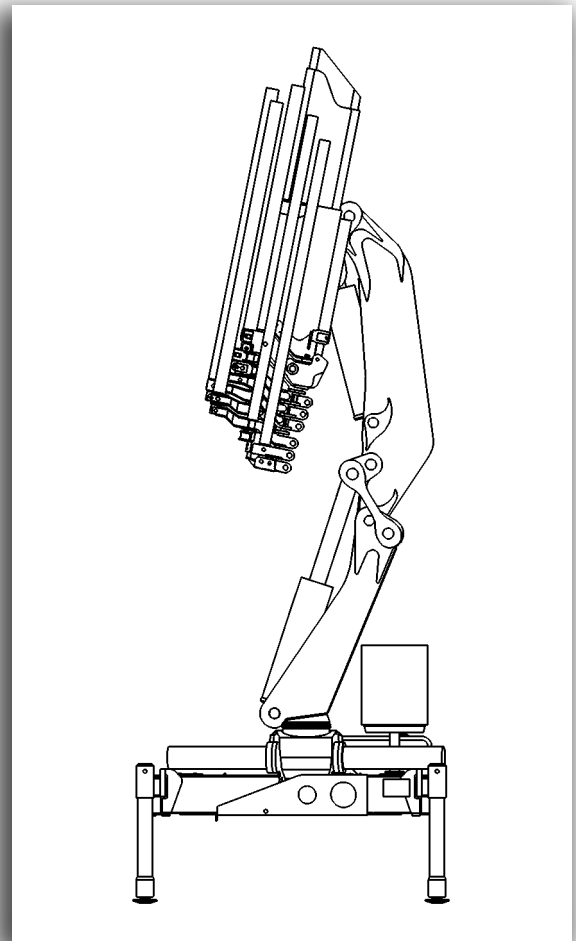
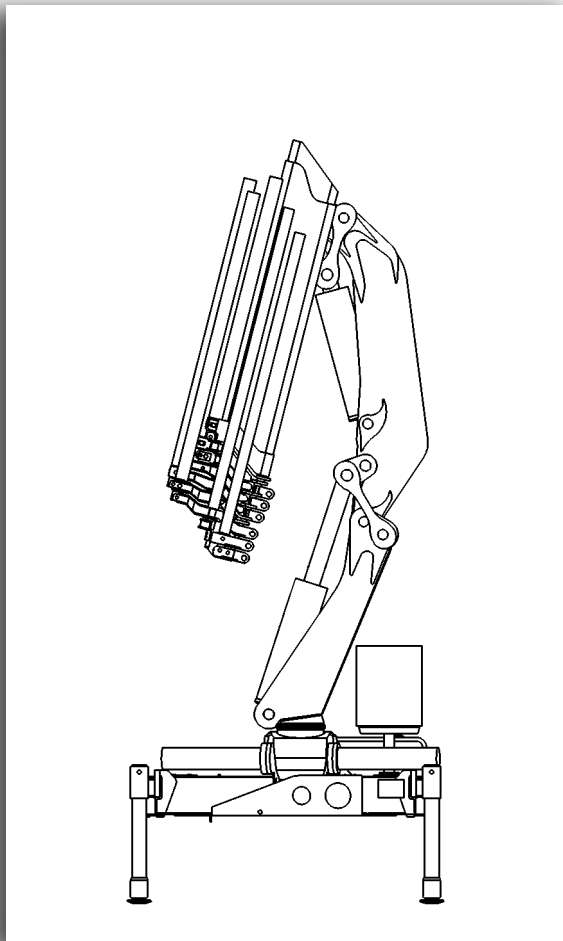

LA FORZA DELLA QUALITÀ THE POWER OF QUALITY
LA FORCE DE LA QUALITE DIE KRAFT DER QUALITÄT LA FUERZA DE LA CALIDAD

45022

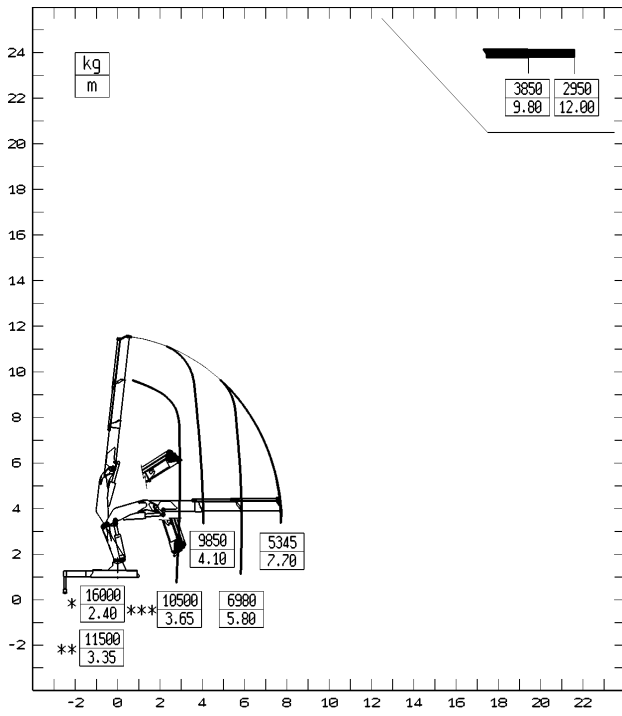

45023

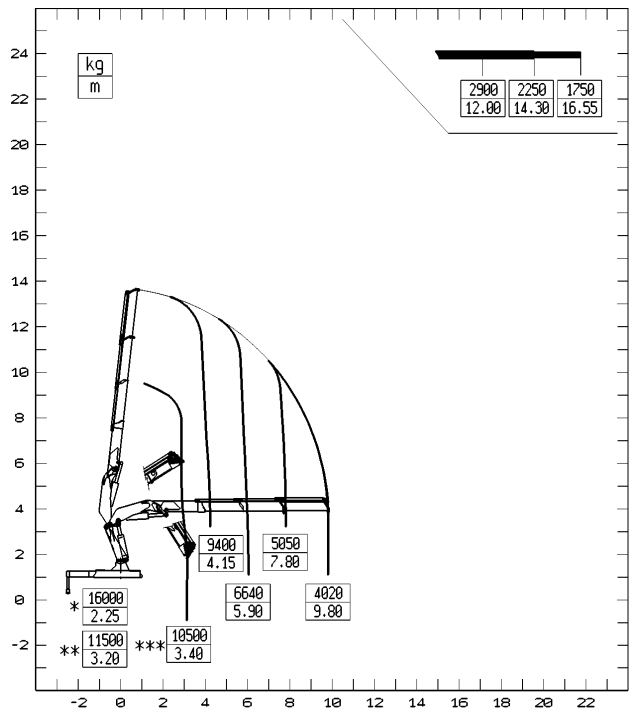

45024

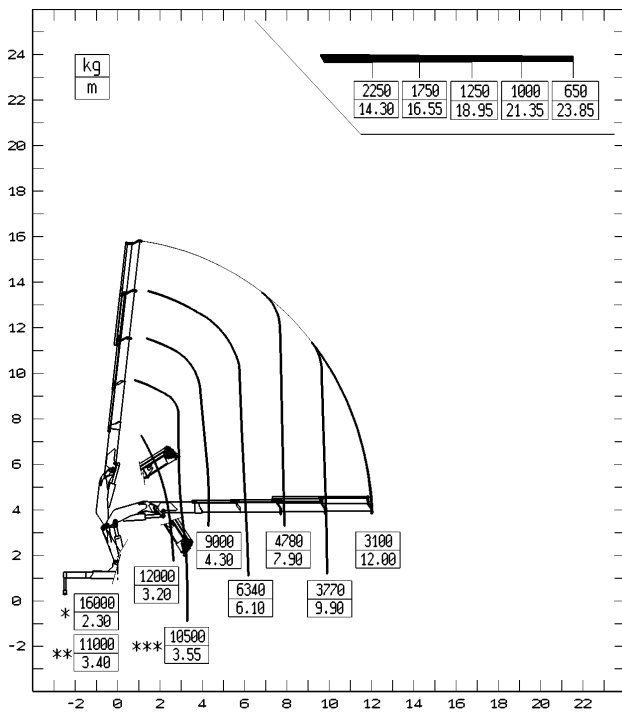

45025

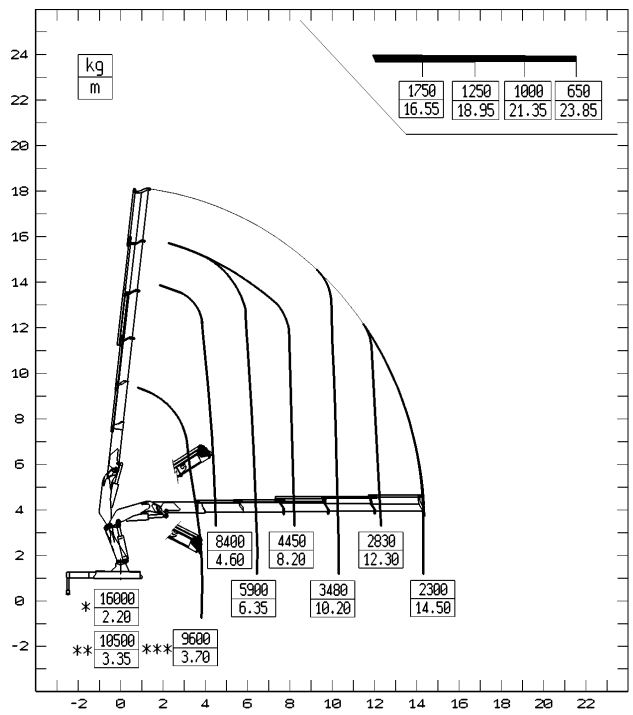

45026

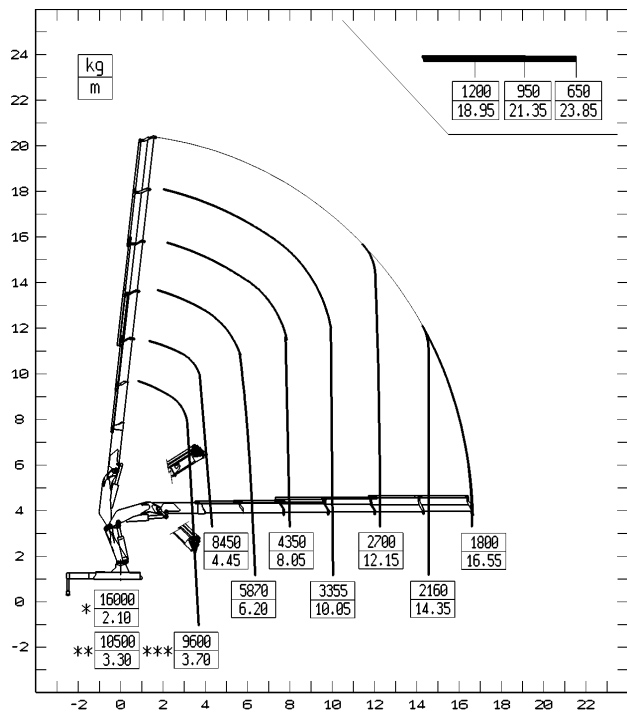

45027

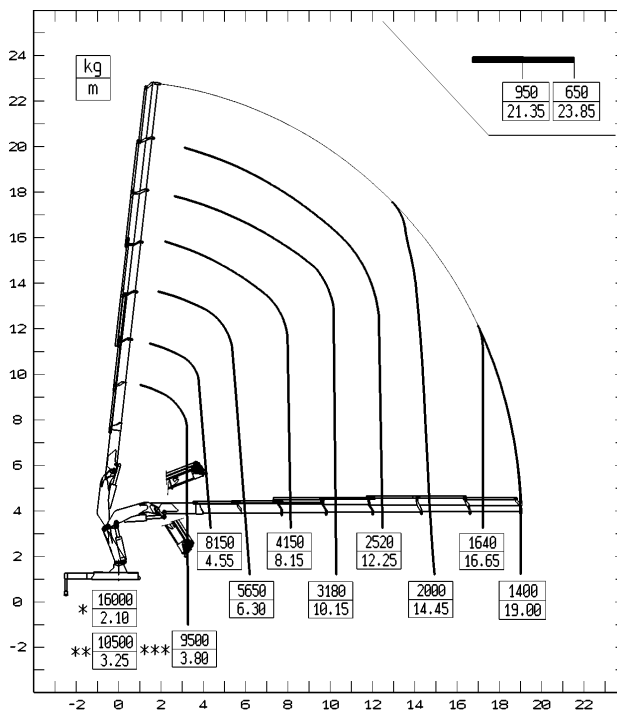

45028

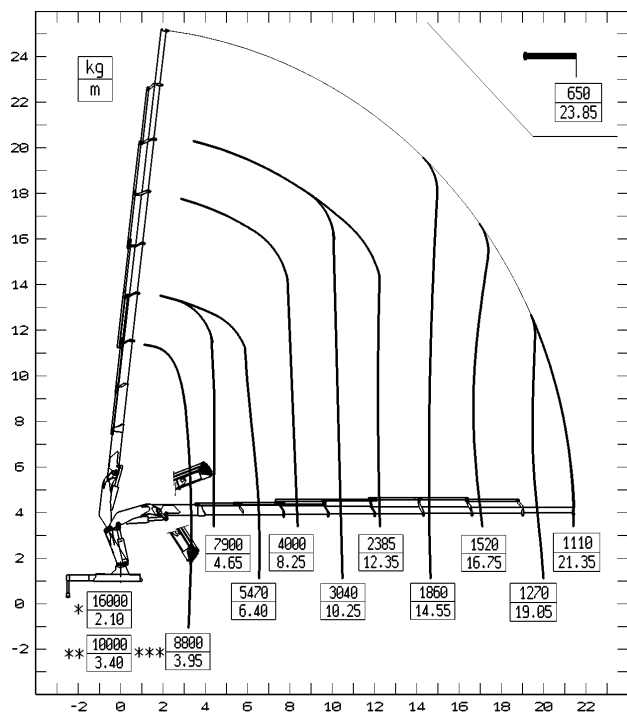

- * PORTATA MASSIMA NOMINALE AL GANCIO FISSO
- ** PORTATA MASSIMA AL GANCIO MOBILE
- *** PORTATA MASSIMA PASSANTE PER L'ORIZZONTALE

N.B.: LE PRESTAZIONI INDICATE SI OTTENGONO CON BRACCIO PRINCIPALE A 15°

- * MAX. NOMINAL CAPACITY WITH FIXED HOOK
- ** MAX. CAPACITY WITH MOBILE HOOK
- *** MAX. CAPACITY FROM HORIZONTAL TO VERTICAL

N.B.: THE STATED PERFORMANCES CAN BE OBTAINED WITH 15° INCLINATED MAIN BOOM

- * CAPACITE MAXI NOMINALE AU CROCHET FIXE
- ** CAPACITE MAXI NOMINALE AU CROCHET MOBILE
- *** CAPACITE MAXI PASSANT PAR L'HORIZONTALE

N.B.: LES PERFORMANCES INDIQUEES S'OBTIENNENT AVEC 1ER BRAS INCLINE A 15°

- * MAX. NENNTRAGKRAFT AN DER INNEREN HAKENBEFESTIGUNG
- ** MAX. TRAGKRAFT
- *** MAX. TRAGKRAFT VON HORIZONTAL BIS ZU VERTIKAL

ANMERKUNG: DIE ANGEGBENEN LEISTUNGEN WERDEN MIT 15° GENEIGTEM HUBRAHMEN ERREICHT

- * CAPACIDAD MÁXIMA EN EL GANCHO FIJO
- ** CAPACIDAD MÁXIMA EN EL GANCHO MÓVIL
- *** CAPACIDAD MÁXIMA EN POSICIÓN VERTICAL

N.B.: LAS PRESTACIONES INDICADAS SE OBTIENEN CON AEL BRAZO ARTICULADO A 15°



45022 LC

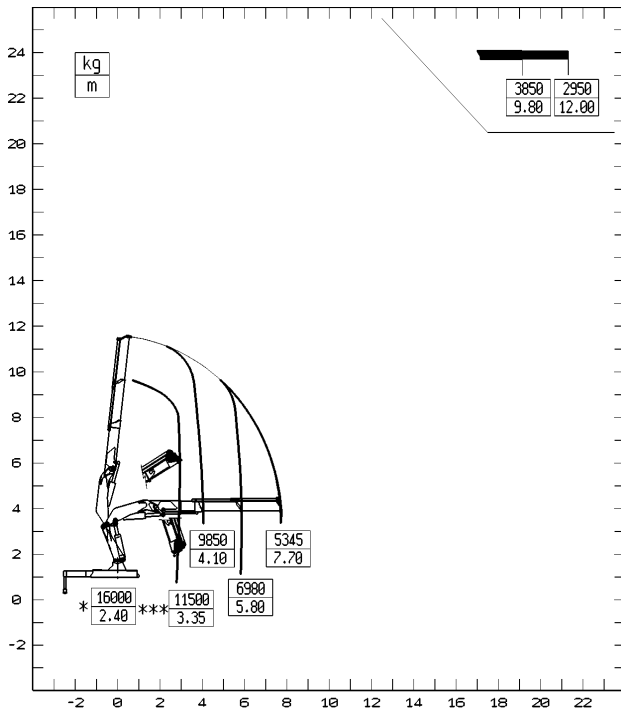

45023 LC

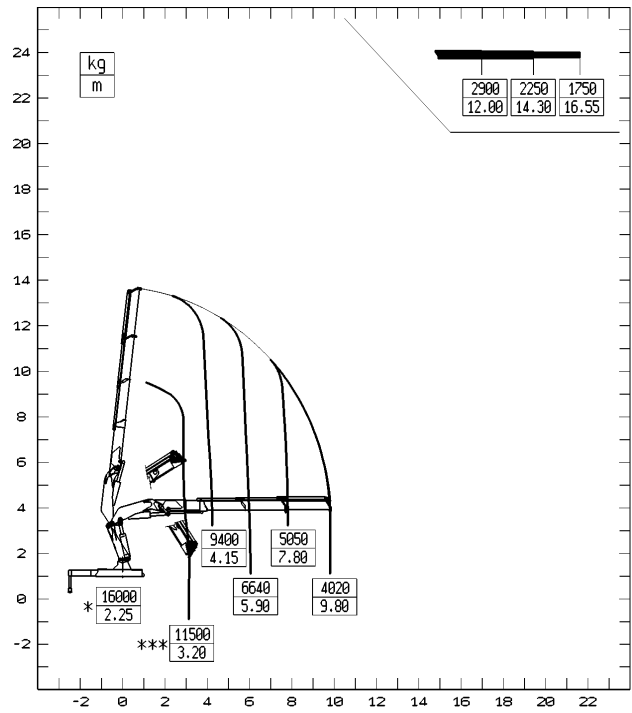

45024 LC

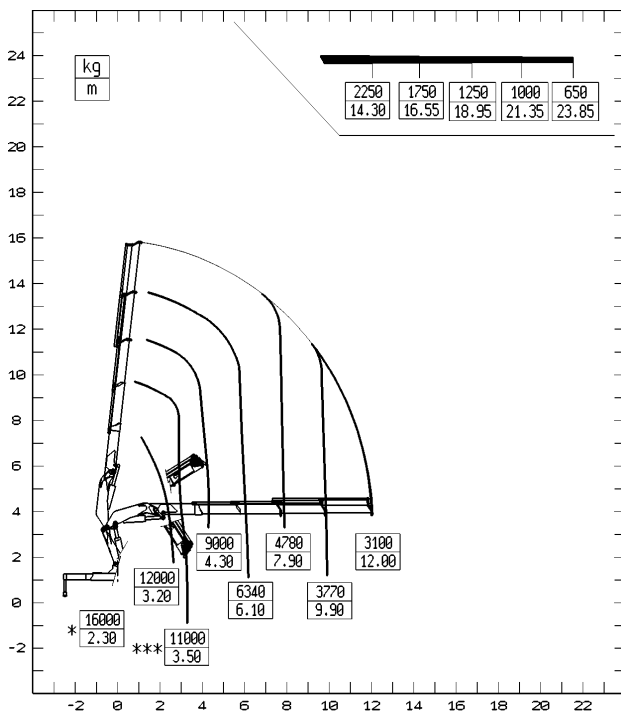

45025 LC

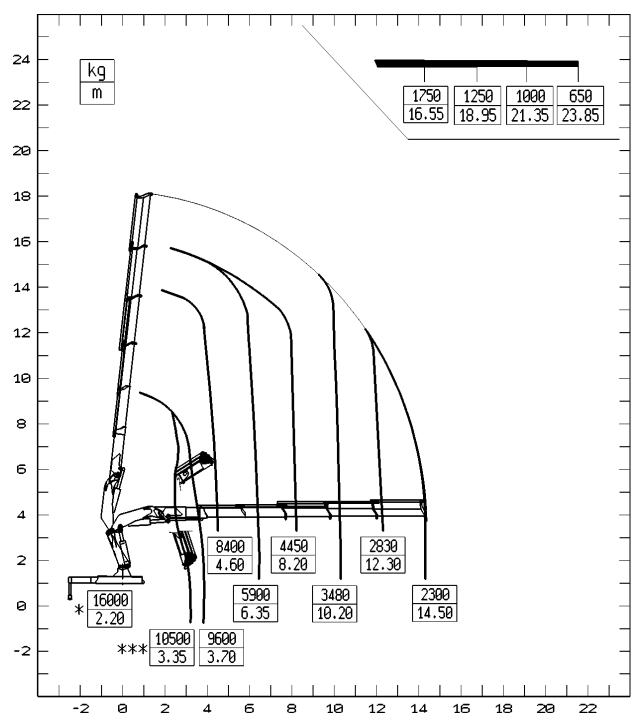

Gru PM, versione LC, con primo braccio retraibile idraulicamente, agevola le movimentazioni ingombranti e gravose a corto raggio, ottimizzando anche le posizioni di carico sotto colonna.

PM crane in LC version, with first hydraulic retractable boom, optimizes the load positioning close to the column, and makes easy the placement of heavy and bulky loads.

PM Ladekrane in CL Ausführung, der hydraulisch einfahrbare Erste Ausleger ermöglicht es sperrige Güter und große Lasten zu heben. Dies wird auch durch die hohe Hakenfreiheit ermöglicht.

45026 LC

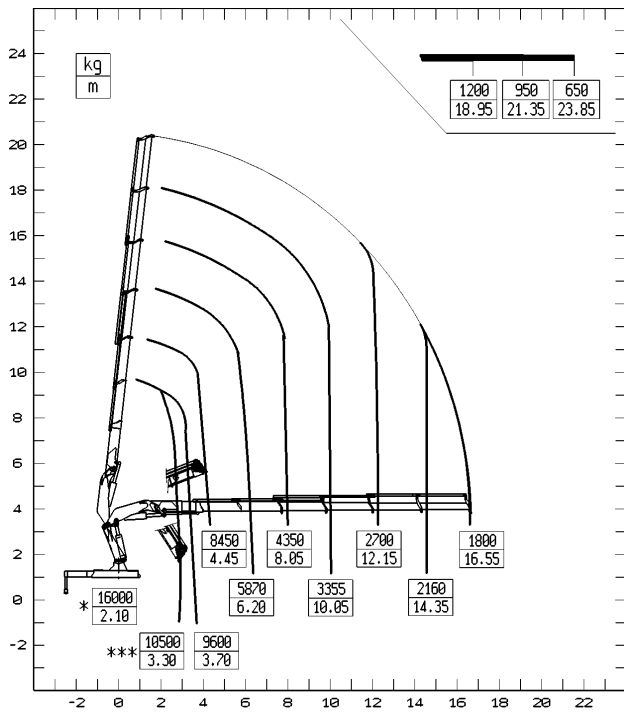

45027 LC

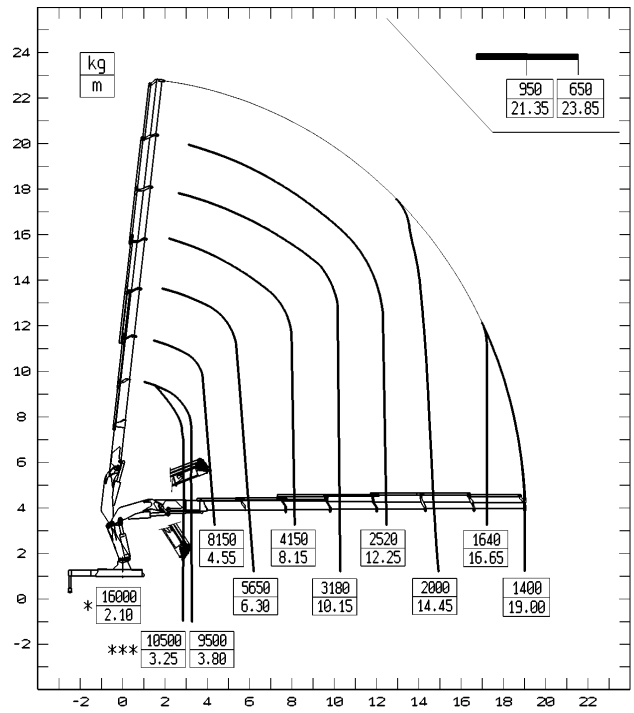

45028 LC

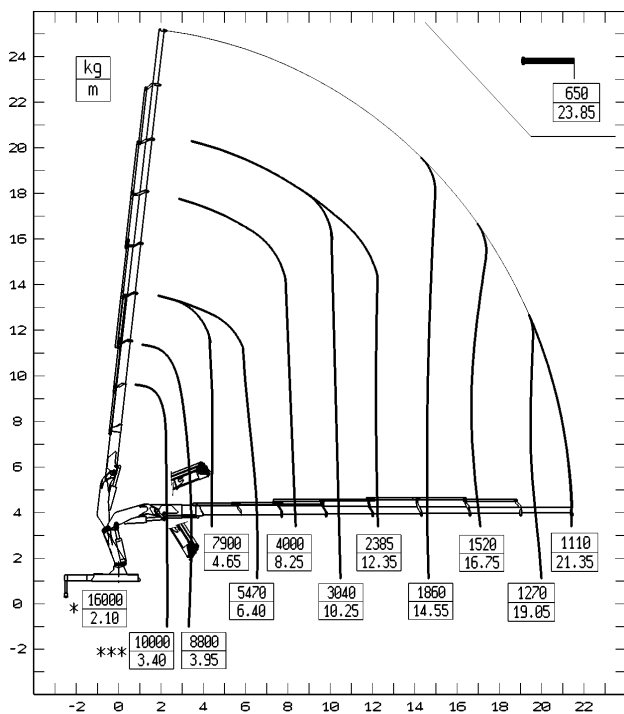

LE ANTENNE IDRAULICHE (J)
POSSONO ESSERE INSTALLATE ANCHE SULLE GRU IN VERSIONE LC

The hydraulic jib can be mounted on the LC version
Les bras articulés (J) peuvent être installés sur les grues en version LC également
Hydraulische Knickarme können auch auf die LC Ausführungen montiert werden
Las antenas hidráulicas se pueden montar también en gruas versión LC

Grue PM, version LC, avec deuxième bras pouvant être raccourci hydrauliquement; cette caractéristique facilite le chargement de matériel lourd et encombrant en augmentant la hauteur disponible sous crochet et la capacité de soulèvement près de la colonne.

Grúas en versión LC, el primero brazo se recoge hidráulicamente, así que permite de elevar, mover y también colocar material pesado y de grande tamaño cerca de la columna.

45024+J903

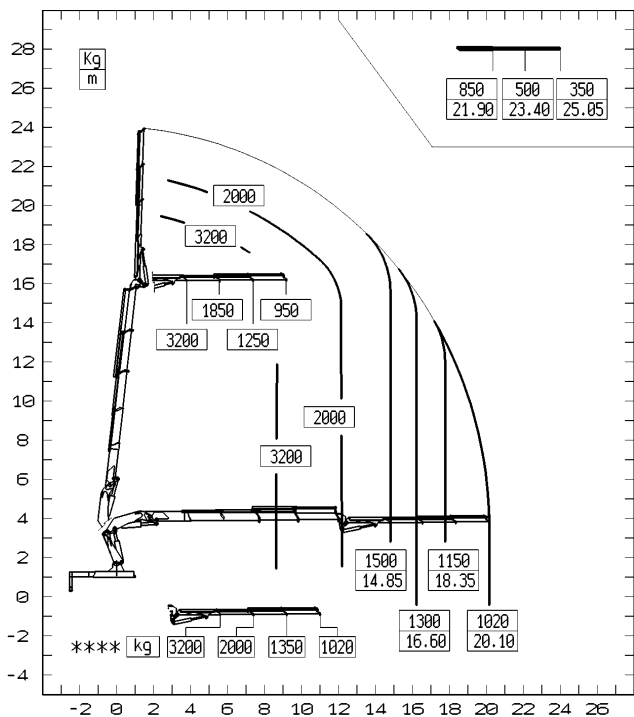

45024+J904

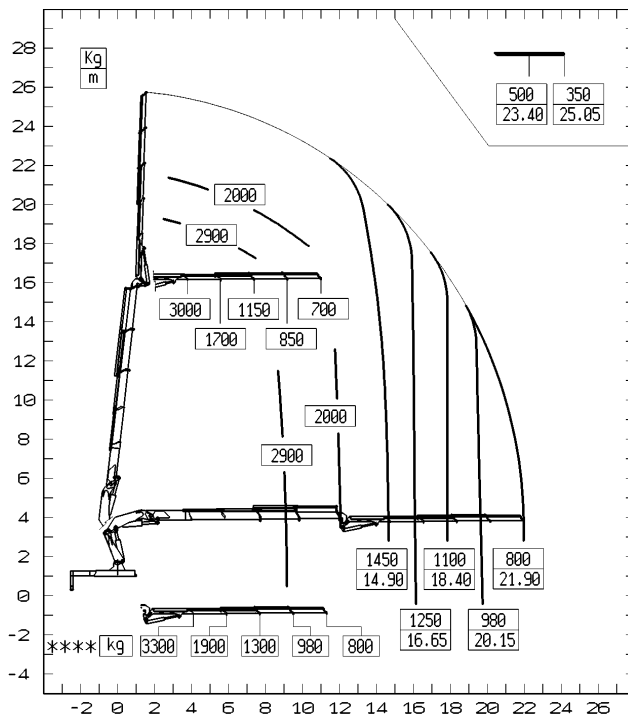

45025+J903

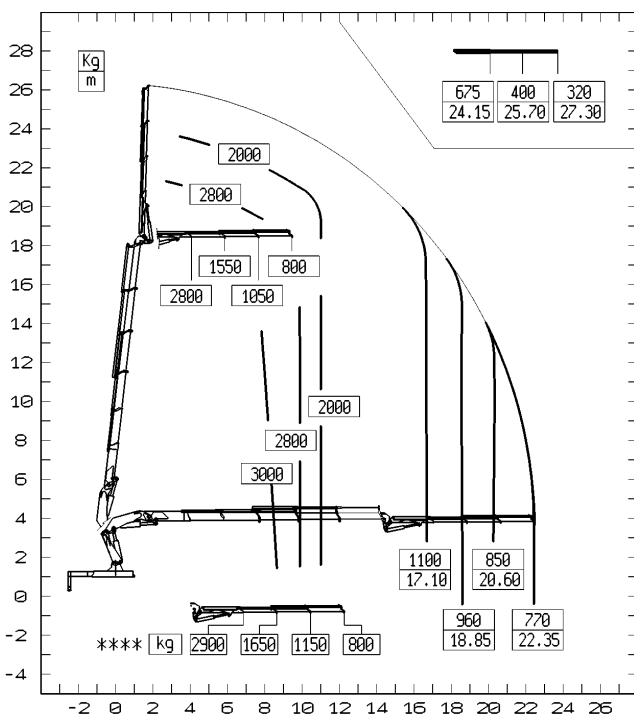

45025+J904

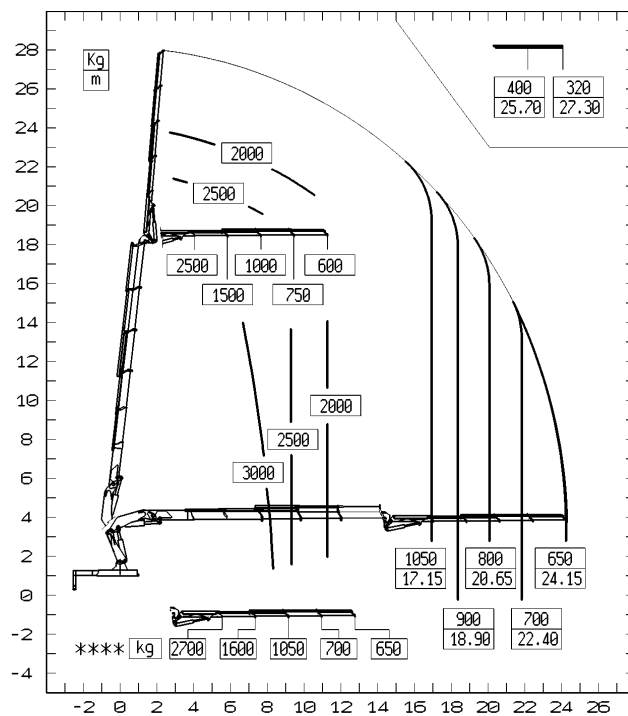

****PORTATE MASSIME DELL'ANTENNA IN ORIZZONTALE
 ***MAX. JIB CAPACITIES IN HORIZONTAL POSITION
 ****CAPACITES MAXI NOMINALES AVEC JIB
 ***MAX. TRAGKRAFTEN AM JIB IN HORIZONTAL
 ****CAPACIDAD MAXIMA DE LA ANTENA EN HORIZONTAL

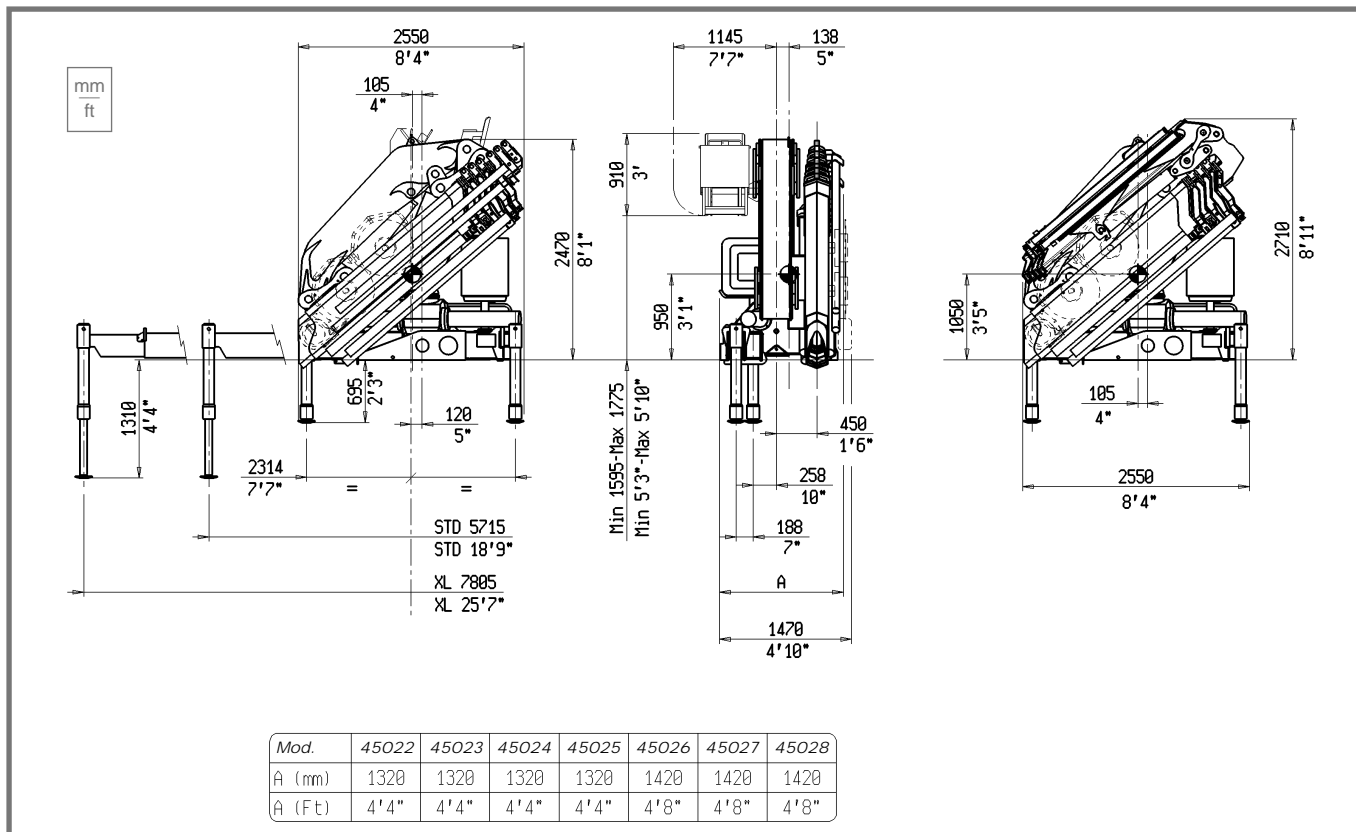

DATI TECNICI - TECHNICAL DATA - DONNÉES TECHNIQUES - TECHNISCHE DATEN - DATOS TECNICOS

45022 45023 45024 45025 45026 45027 45028 45024 +J903 45024 +J904 45025 +J903 45025 +J904

MOMENTO DI SOLLEVAMENTO MASSIMO

Maximum lifting moment - Moment de levage maxi - Max. Lastmoment - Momento de elevación máxima	kNm	404	386	380	379	369	364	360	--	--	--	--
	tm	41,2	39,4	38,7	38,6	37,6	37,1	36,7	--	--	--	--

SBRACCIO OLEODINAMICO

Maximum hydraulic reach - Allongement hydraulique - Hydraulische Reichweite, Standard - Alcance hidráulico												
ORIZZONTALE - Horizontal - Horizontal - Horizontal - Horizontal	m	7,80	9,90	12,10	14,60	16,65	19,10	21,45	20,20	22,00	22,45	24,25
VERTICALE - Vertical - Vertical - Vertikal - Vertical	m	11,45	13,54	15,70	18,00	20,20	22,50	24,90	23,95	25,75	26,20	27,95

SBRACCIO CON PROLUNGHE

Maximum reach with manual extensions - Allongement avec rallonges manuelles - Reichweite, manuelle Verlängerungen - Alcance con prolongas manuales												
ORIZZONTALE - Horizontal - Horizontal - Horizontal - Horizontal	m	12,10	16,65	24,00	24,00	24,00	24,00	24,00	25,15	25,15	27,40	27,40
VERTICALE - Vertical - Vertical - Vertikal - Vertical	m	15,85	20,30	27,60	27,60	27,60	27,60	27,60	29,40	29,40	31,70	31,70

IMPIANTO OLEODINAMICO - Hydraulic system - Circuit hydraulique - Hydraulikanlage - Sistema hidráulico

PORTATA RACCOMANDATA - Recommended oil flow - Débit recommandé - Empfohlene Fördermenge - Caudal requerido	l/min	45	45	45	45	45	45	45	45	45	45	45
PRESSIONE MASSIMA - Rated pressure - Pression maxi - Betriebsdruck - Presión máxima	MPa	31	31	31	31	31	31	31	29	29	29	29
CAPACITÀ DEL SERBATOIO - Tank capacity - Capacité du réservoir - Tankinhalt - Capacidad del depósito de aceite	l	200	200	200	200	200	200	200	200	200	200	200

GRUPPO DI ROTAZIONE - Slewing system - Rotation - Schwenksystem - Sistema de giro

ANGOLO DI ROTAZIONE - Slewing angle - Angle de rotation - Schwenkbereich - Ángulo de giro	°	400	400	400	400	400	400	400	400	400	400	400
COPPIA DI ROTAZIONE - Slewing moment - Couple de rotation - Schwenkmoment - Momento de giro	kNm	40	40	40	40	40	40	40	40	40	40	40
PENDENZA MASSIMA DI LAVORO - Max. working heel - Devers maxi de travail - Max. Arbeitsneigung - Inclinación máxima de trabajo	% (°)	8,7(5)	8,7(5)	8,7(5)	8,7(5)	8,7(5)	8,7(5)	8,7(5)	8,7(5)	8,7(5)	8,7(5)	8,7(5)

PESO GRU STANDARD - Standard crane weight - Poids de la grue standard - Eigengewicht - Peso de la grúa est

IN VERSIONE LC - LC Version	Kg	4360	4620	4850	5070	5260	5420	5570	5660	5740	5880	5960
CON SERBATOIO NON RIFORNITO - Empty oil tank - Reservoir huile non garni - Oeltank leer - Deposito de aceite vacío	Kg	4510	4770	5000	5220	5410	5570	5720	5810	5890	6030	6110

TUTTE LE GRU PM SONO COPERTE DA POLIZZA ASSICURATIVA INTERNAZIONALE PER LA RESPONSABILITÀ CIVILE VERSO TERZI
 ALL PM CRANES ARE COVERED BY AN INTERNATIONAL INSURANCE POLICY FOR CIVIL LIABILITY THIRD PARTY
 TOUTES LES GRUES SONT COUVERTES PAR UNE POLICE D'ASSURANCE INTERNATIONALE DE RESPONSABILITE CIVILE ENVERS TIERS
 PM-KRÄNE SIND DURCH EINE INTERNATIONALE HAFTPFLICHTVERSICHERUNG GEGEN DRITTE ABGESICHERT
 TODAS LAS GRUAS PM CUENTAN CON UNA PÓLIZA DE SEGUROS INTERNACIONAL CONTRA LAS RESPONSABILIDADES CIVILES HACIA TERCEROS

CRANES, IN ALL THE LANGUAGES OF THE WORLD

ARGENTINA
AUSTRALIA
BELGIUM
BRAZIL
CANADA
CHILE
COLOMBIA
CZECH REP
CYPRUS
DENMARK
EGYPT
EAST/NORTH EUROPE
EIRE
FINLAND
FRANCE
GERMANY
GREECE
HOLLAND
HONG KONG
INDONESIA
ITALY
JORDAN
MALAYSIA
MOROCCO
NORWAY
OCEANIA
NETHERLANDS
PERU
PHILIPPINES
POLAND
PORTUGAL
P.R.C.
QUATAR
ROMANIA
SAUDI ARABIA
SINGAPORE
SPAIN
SOUTH AFRICA
SOUTH AMERICA
SWITZERLAND
THAILAND
TAIWAN
TOBAGO
TRINIDAD
TUNISIA
TURKEY
UNITED ARAB EMIRATES
USA
UK
VENEZUELA
VIETNAM



Autogru PM spa - via Emilia Est, 1058 - 41100 Modena MO (ITALY)
Tel. +39 059 20.54.711 - Fax +39 059 28.07.47 - Export Fax +39 059 28.25.05
e-mail: autogrupm@autogrupm.com www.autogrupm.com